

**Research Project:** Nano particle reinforced composites for critical infrastructure protection

**Research Topic:** Blast and impact simulation of structural components by AUTODYN

**Problem**

This part of the workplan includes the evaluation of structural components made of normal strength concrete, nanoparticle reinforced concrete, retrofitted concrete using FRP, retrofitted concrete using polyurea, and the new generation of carbon and clay nano-reinforced polymers.

**Approach**

Computational simulations of structural components and subsystems, with and without retrofit, using material parameters appropriate to the conventional or nano-composite material, and subject to severe loading environment, are conducted.

AUTODYN is commercial computer software for modeling non-linear dynamics of solids, fluids, gas and their interaction. AUTODYN hydrocode is capable of computing strains, stresses, velocities and propagation of shock wave as a function of time and position. Different models, which include Lagrange, Lagrange-Euler coupling, Lagrange-SPH models, are used to evaluate the blast effect. In the hydrocode simulation, the response of a continuum subjected to dynamic loading is governed by conservation of mass, momentum and energy, and also Equation Of State (EOS) and constitutive relation. The EOS takes into account the effect of compressibility of the continuum.

The computational results will be compared with the blast simulation conducted in the laboratories of the US Army Engineering Development and Research Center, a partner of the present project. The figure below shows a blast experiment of a concrete masonry unit (CMU) retrofitted by a spray-on polymeric membrane subjected to a blast.

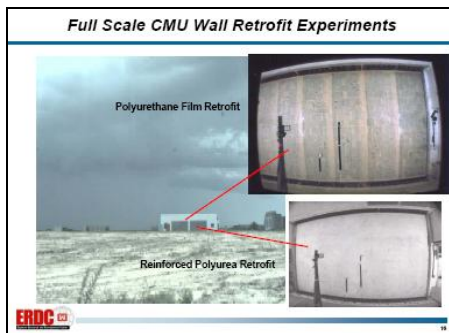

**Findings**

Initial runs are made on ballistic/projectile loading on walls made of various materials using the AUTODYN software. The following findings may be reported:

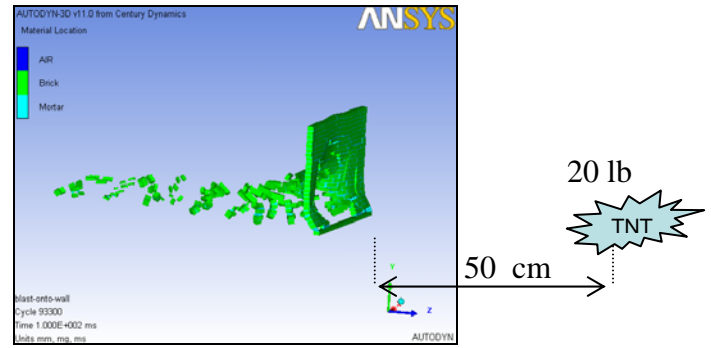

Un-retrofitted brick wall subjected to blast loading

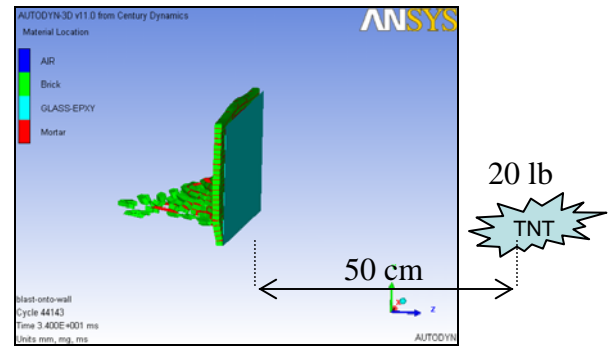

Retrofitted brick wall with FRP subjected to blast loading from the direction of the retrofit

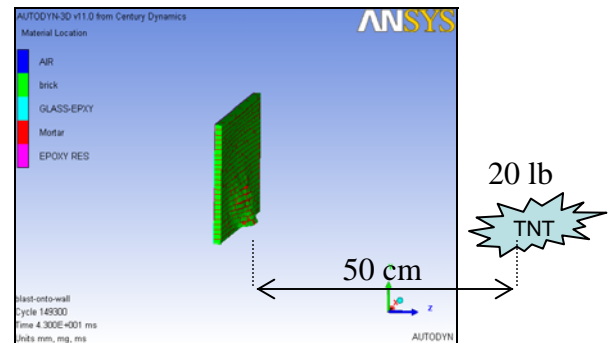

Retrofitted brick wall with FRP subjected to blast loading from the opposite direction of the retrofit

1. Trial runs with a blast loading due to the detonation of 20lb TNT at 50 cm in front of brick walls with and without glass epoxy retrofits have been conducted. The results show that glass epoxy is not capable of containing blast damage. The main cause of damage was observed to be the reflective wave.
2. FRP reinforcement is found to be effective in protecting the brick wall. The reinforcement should be installed in the back of the wall, not the front.

**Impact**

Outcome of this research can build a database for structure component retrofitting strategies.

**Researcher:** Drs. Ahmed Al-Ostaz and Chris Mullen are Associate Professors, and Mr. Mohammad Irshidat is a graduate student, in the Department of Civil Engineering at University of Mississippi.

(Last update: August 2007)